

Алматы (727)345-47-04
Ангарск (3955)60-70-56
Архангельск (8182)63-90-72
Астрахань (8512)99-46-04
Барнаул (3852)73-04-60
Белгород (4722)40-23-64
Благовещенск (4162)22-76-07
Брянск (4832)59-03-52
Владивосток (423)249-28-31
Владикавказ (8672)28-90-48
Владимир (4922)49-43-18
Волгоград (844)278-03-48
Вологда (8172)26-41-59
Воронеж (473)204-51-73
Екатеринбург (343)384-55-89

Россия +7(495)268-04-70

Иваново (4932)77-34-06
Ижевск (3412)26-03-58
Иркутск (395)279-98-46
Казань (843)206-01-48
Калининград (4012)72-03-81
Калуга (4842)92-23-67
Кемерово (3842)65-04-62
Киров (8332)68-02-04
Коломна (4966)23-41-49
Кострома (4942)77-07-48
Краснодар (861)203-40-90
Красноярск (391)204-63-61
Курск (4712)77-13-04
Курган (3522)50-90-47
Липецк (4742)52-20-81

Казахстан +7(727)345-47-04

Магнитогорск (3519)55-03-13
Москва (495)268-04-70
Набережные Челны (8552)20-53-41
Нижний Новгород (831)429-08-12
Новокузнецк (3843)20-46-81
Ноябрьск (3496)41-32-12
Новосибирск (383)227-86-73
Омск (3812)21-46-40
Орел (4862)44-53-42
Оренбург (3532)37-68-04
Пенза (8412)22-31-16
Петрозаводск (8142)55-98-37
Псков (8112)59-10-37
Пермь (342)205-81-47

Беларусь +(375)257-127-884

Ростов-на-Дону (863)308-18-15
Рязань (4912)46-61-64
Самара (846)206-03-16
Санкт-Петербург (812)309-46-40
Саранск (8342)22-96-24
Саратов (845)249-38-78
Севастополь (8692)22-31-93
Симферополь (3652)67-13-56
Смоленск (4812)29-41-54
Сочи (862)225-72-31
Ставрополь (8652)20-65-13
Сургут (3462)77-98-35
Сыктывкар (8212)25-95-17
Тамбов (4752)50-40-97
Тверь (4822)63-31-35

Узбекистан +998(71)205-18-59

Тольятти (8482)63-91-07
Томск (3822)98-41-53
Тула (4872)33-79-87
Тюмень (3452)66-21-18
Улан-Удэ (3012)59-97-51
Ульяновск (8422)24-23-59
Уфа (347)229-48-12
Хабаровск (4212)92-98-04
Чебоксары (8352)28-53-07
Челябинск (351)202-03-61
Череповец (8202)49-02-64
Чита (3022)38-34-83
Якутск (4112)23-90-97
Ярославль (4852)69-52-93

Киргизия +996(312)96-26-47

<https://rechner.nt-rt.ru> || ret@nt-rt.ru

КАТАЛОГ емкостных датчиков eXtreme

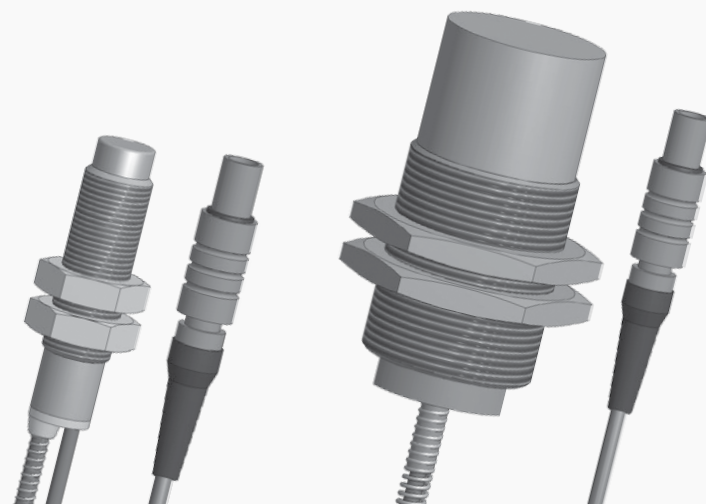

CAPACITIVE SENSORS eXtreme

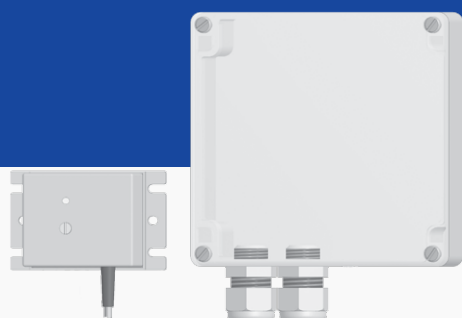

RECHNER
SENSORS

eXtreme
Range

CAPACITIVE SENSORS KXS-eXtreme

	PAGES
TECHNOLOGY MOUNTING APPLICATION	4 - 6
TECHNICAL TERMS	7
APPLICATION EXAMPLES	8
TYPE CODE	9 - 12
eXtreme SENSORS & EVALUATION UNITS	15 - 33
ATEX	35
ATEX eXtreme SENSORS & EVALUATION UNITS	36 - 37

KXS-eXtreme series:**Extremely high sensitivity****Extended temperature range**

**-50°C to
+250°C

+800°C**

The capacitive proximity sensors that make up the Classic-model series (KAS-...) are already established as powerful leaders in today's market. They are well accepted as sensors that are reliable, and there are a large number of versions to suit many applications in the processing industry and throughout mechanical engineering. Nowadays they are indispensable. Important parameters for the user are the achievable switching distance and the size of the sensor. Larger switching distances normally require larger sensors.

It is here that the new KXS/KXA-Systems show their strength. Although one achieves essentially larger switching distances with these capacitive systems, their size is actually smaller.

The sensors of the KXS/KXA-eXtreme Series are based on a different measuring principle, the three-electrode-principle:

- Extreme large sensing distance, up to 10-times the norm
- Miniature sensors from M 5
- Measurement of the smallest changes in capacity
- Suitable for high-temperature areas up to +250° C (ceramics +800° C)
- Duplex, Triplex, Quattroplex operation (up to 4 adjustable switching points in one sensor)

With this Measuring principle, one electrode BE (BE = function earth) is moved to the outside. The protective conductor-potential PE – that means the machine and system potential – is now also used as a measurement electrode (= function earth). The evaluation takes place with remote electronics.

Thanks to the remote evaluation electronics and the housing materials used, the standard types of capacitive sensors of the KXS- / KXA-Systems are suitable for use in high-temperature areas up to +250°. For particular applications, sensors are available in stainless steel / ceramic housings that can be used up to 800° C.

Sensors

Our **KXS-eXtreme** sensors have a cylindrical design with threads from M 5 to M 32

Evaluation unit

The following types are available as evaluation units:

- KXA-5-1-... to connect one sensor KXS-... with one limit switching point
- KXA-5-4-... to connect up to 4 KXS-... sensors with one limit switching point
- KXA-5-1/4-... to connect one sensor KXS-... duplex, triplex or quattroplex application (= up to 4 limit switching points)

Application example:

- | | | |
|------------------------------|---|-----------------------|
| ➤ No target at sensor | = | No output signal |
| ➤ Empty glass-bottle present | = | Output signal 1 |
| ➤ Full glass-bottle | = | Output signal 1 and 2 |

Easy commissioning

It is easy to put the capacitive system in to operation:

Mechanical mounting of the sensor + electrical connection + adjustment = ready for operation.

If the sensor is not screwed into metal, please note that a galvanic connection must be made from the electronics to the protective conductor potential.

TECHNOLOGY • MOUNTING • APPLICATION

DEPENDENT ON THE APPLICATION THERE ARE TWO MOUNTING VARIANTS:

1. NON-FLUSH MOUNTABLE

= FOR CONTACT WITH PRODUCTS



For the level control of liquids or bulk material in most cases the sensors are used in such a way, that the active surface of the sensor comes in direct contact with the material to be detected.

Dependent on the material to be detected specific requirements to the housing designs have to be considered. Especially for that part which is in direct contact with the product.

2 mounting variants:

Non-flush mountable

Flush mountable

2. FLUSH MOUNTABLE

= AT DISTANCE OR THROUGH THE CONTAINER WALL



Besides product-touching level control there is the option of level control through a non-metal container wall. The thickness of the container wall should not exceed 4 mm at the place where the measurement is made.

Furthermore the flush mountable sensors are often used for the position control of objects.

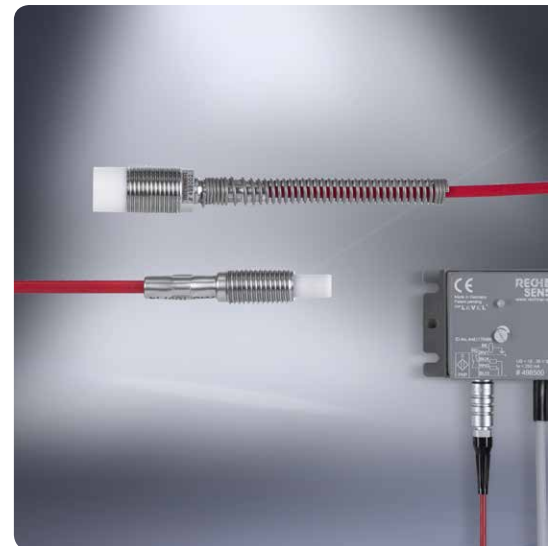

3-electrode-principle

One electrode is moved to the outside
(BE = function earth)

Maximum torque

In order to prevent damage to the threaded sleeves when mounting, the material and version-dependent maximum torque should be taken into consideration. The values listed in the table are based on the use of the nuts supplied with the sensors.

Maximum torque		
Thread	PPO	VA
M 5 x 0,5	-	1,5 Nm
M 8 x 1	-	4,5 Nm
M 12 x 1	1 Nm	15 Nm
M 18 x 1	3 Nm	40 Nm
M 30 x 1,5	8 Nm	150 Nm
M 32 x 1,5	13 Nm	180 Nm

Maximum screw-in length according to DIN 13

Due to the permitted thread tolerances specified in German standard DIN 13, the maximum screw-in length for threaded sensors should be taken into consideration. Based on this the length of the threaded block for screwing in proximity sensors should not exceed the following dimensions. Where a larger threaded block is used we recommend drilling a blind hole in order to adhere to the maximum screw-in length.

Thread	M 5 x 0,5	M 8 x 1	M 12 x 1	M 18 x 1	M 30 x 1,5	M 32 x 1,5
Max. screw-in length	3 mm	6 mm	8 mm	12 mm	12 mm	12 mm

Wiring

The control wires of the capacitive sensors should be routed separately or screened from large value conducting cables, as in extreme cases inductive peak voltages can destroy the sensors despite the integrated protective circuit. Screened cable or twisted lines are especially recommended for long cable runs > 5 m. Direct control of electric light bulbs should be avoided, as during the switch-on moment the cold current is many times the rated current and can destroy the output stage of the sensor.

Nominal sensing distance according to DIN EN 60947-5-2

The data for the nominal sensing distance is based on the measuring method defined by DIN VDE 0660, Part 208. The respective nominal sensing distance is indicated with a tolerance of + 10 %. The standard measurement plate is square with a thickness of 1 mm and is made of carbon steel FE 360 (defined in ISO 630: 1980) with a smoothed surface and is grounded. The sides are equal to the diameter of the active area of the KAS or equal to 3 x Sn, depending on which value is greater. With a different material or a smaller surface of the actuating element, the sensing distance is smaller.

Housing materials

The application of the housing materials used is based on the technical specifications of the material and of the manufacturer. Even though RECHNER Sensors have far-reaching application experience concerning the use of different housing materials, the customer is responsible for checking in each case that the housing material is suitable for the application.

Cable

For the standard models COAX-, TRIAX-, PVC- or PUR-cable are used. One has to take into consideration that the cable should not be moved with ambient temperatures below -5°C . PVC is not suitable for use in applications with oil-based liquids or with UV-radiation. PUR is not suitable for continuous contact with water. For special application areas silicone or PTFE cables are available. COAX- and TRIAX-Cable are not designed for continuous movement / flexible use. When routing please consider the bending radius of minimum $10 \times \varnothing$.

Sensing distance S_n

Characteristic value of a proximity sensor, without consideration of production tolerances and variations due to temperature and voltages.

Enclosure rating

IP 54: Protected against dust in harmful quantities, complete protection against contact and protection against splashing water on all sides.

IP 65: Protection against contact with voltage-carrying parts, protection against ingress of dust and water jets.

IP 67: Protection against contact with voltage-carrying parts, protection against ingress of dust and protection against ingress of water when the equipment is immersed in water, up to 1 m depths for a period of 30 minutes.

Voltage drop U_d

Voltage drop is the voltage, which is at the active output of the sensor in the on state.

Repeat accuracy

Measurement of the sensing distance in succession, which is made at constant ambient conditions.

Permitted residual ripple

The permitted residual ripple of the used power pack, used as power supply.

The products of Rechner Industrie-Elektronik GmbH are designed and checked in accordance with the latest standards and specifications, DIN - VDE - IEC, for electrical and electronic instruments. For new and revised products the newest standards are always used.

APPLICATION EXAMPLES

2 non-flush mountable sensors for min/max monitoring are used

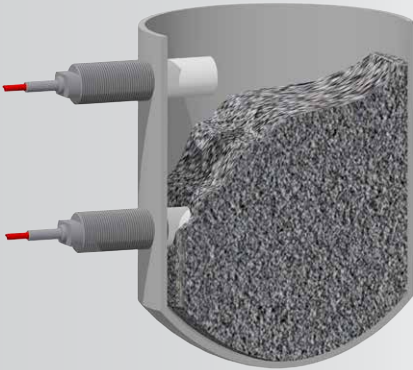

Application in a container with granules

Filling level control

The capacitive sensors of the **KXS / KXA-eXtreme** series are suitable for level monitoring of liquids, pastes and bulk solids in machines and plants, even through non-metallic partitions.

- High temperature range up to +250°C
- For hotmelt / hot glue
- For applications where the classic capacitive sensors are at their limits, the special strength of the **KXS-eXtreme** sensors is needed

Position check

The capacitive sensors of the **KXS / KXA-eXtreme** series can be used as limit switches, non-contact limit switches, for monitoring and positioning, as pulse generators for counting tasks and much more.

A possibility for Duplex-Function, with this example, the limit switching point S₂ is indicating "bottle filled with water"

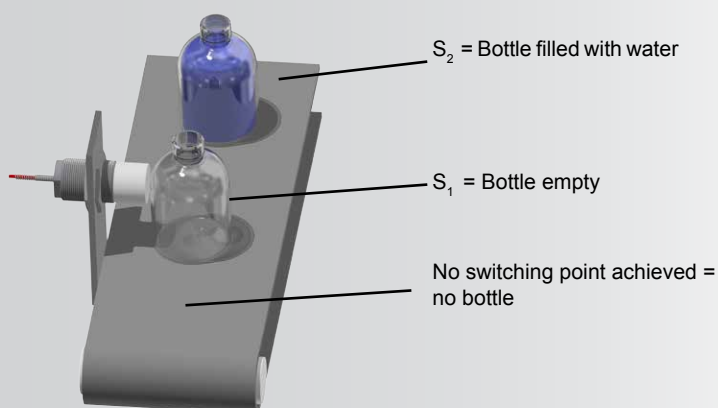

Duplex-application
(with one Quattroplex evaluation unit up to 4 switching points in one sensor)

TYPE CODE

Example:

KXS - 250 -M32/70- X - M32 - PEEK - 250C -X02/Y95

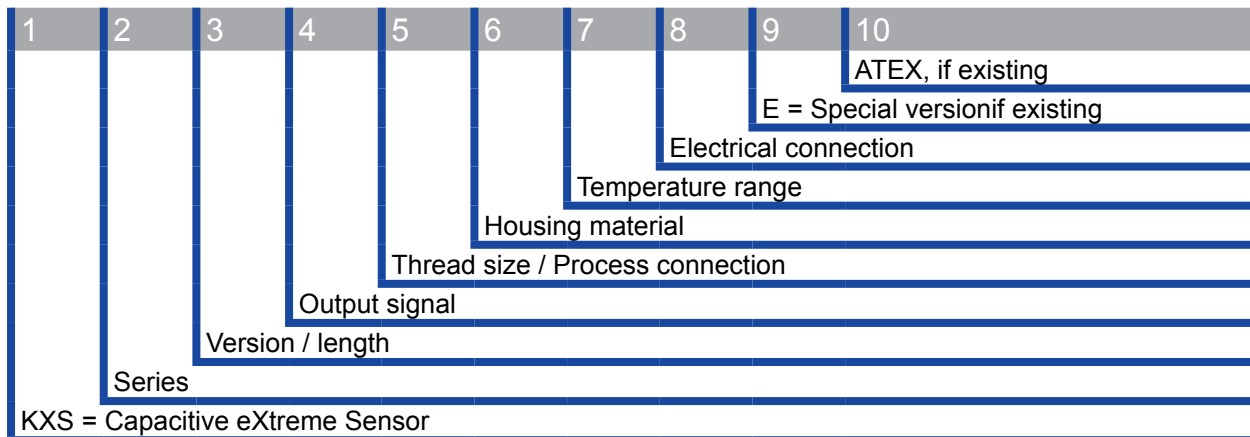

Position 2

Value	Series	Function
250	High temperature sensor	Sensor passive

Position 3

Value	Body size (Ø = mm)	Cylindrical	Mounting version
M5/20	M 5 x 0,5	Yes	Non-Flush
M8/25	M 8 x 1	Yes	Non-Flush
M12/25	M 12 x 1	Yes	Non-Flush
M12/50	M 12 x 1	Yes	Non-Flush
M16/30	M 16 x 1	Yes	Flush
M18/70	M 18 x 1	Yes	Non-Flush
18/10	Ø 30	Yes	Non-Flush
22/10	Ø 22	Yes	Non-Flush
28/73	Ø 28	Yes	Non-Flush
M30/50	M 30 x 1,5	Yes	Flush
30/70	Ø 30	Yes	Non-Flush
M30/70	M 30 x 1,5	Yes	Non-Flush
M32/70	M 32 x 1,5	Yes	Non-Flush
G1/2/100	G 1/2"	Yes	Non-Flush

Position 4

Value	Output signal
X	Passive

TYPE CODE
Position 5c

Value	Thread / Process connection
M5	M 5 x 0,5
M8	M 8 x 1
M12	M 12 x 1
M16	M 16 x 1
M18	M 18 x 1
M30	M 30 x 1,5
M32	M 32 x 1,5
D22	Ø 22 mm
D28	Ø 28 mm

Position 6

Material	Active surface	Housing
Ceramic/VAb	Ceramics	Stainless steel No. 1.4305 (AISI 303)
PEEK	Polyetheretherketone FDA 21 CFR 177.2415	Polyetheretherketone FDA 21 CFR 177.2415
PEEK/VAb	Polyetheretherketone FDA 21 CFR 177.2415	Stainless steel No. 1.4305 (AISI 303)
PPO	Polyphenylenoxide	Polyphenylenoxide
PTFE	Polytetrafluoroethylene FDA 21 CFR 177.1550	Polytetrafluoroethylene FDA 21 CFR 177.1550
PTFE/VAb	Polytetrafluoroethylene FDA 21 CFR 177.1550	Stainless steel No. 1.4305 (AISI 303)

Position 7

Value	Temperature range
70C	70 °C
160C	160 °C
250C	250 °C
800C	800 °C

Position 8

Value	Electrical connection
X0E/Y95	Special cable length / Connection to evaluation unit Y90
X02/Y95	Connection cable, 2 m / Connection to evaluation unit Y90
X03/Y95	Connection cable, 3 m / Connection to evaluation unit Y90
X05/Y95	Connection cable, 5 m / Connection to evaluation unit Y90

Position 9

Value	Special version
Not specified	Standard version
E	Special version

Position 10

Value	Device for use in areas with the risk of explosion
3D	With manufacturer declaration for ATEX zone 22
3G	With manufacturer declaration for ATEX zone 2
3D3G	With manufacturer declaration for ATEX zone 22 and 2

TYPE CODE EVALUATION UNIT

Example: Capacitive eXtreme evaluation unit

KXA - 5 - 4 - XXL - P - S - 4FB

KL - Y90

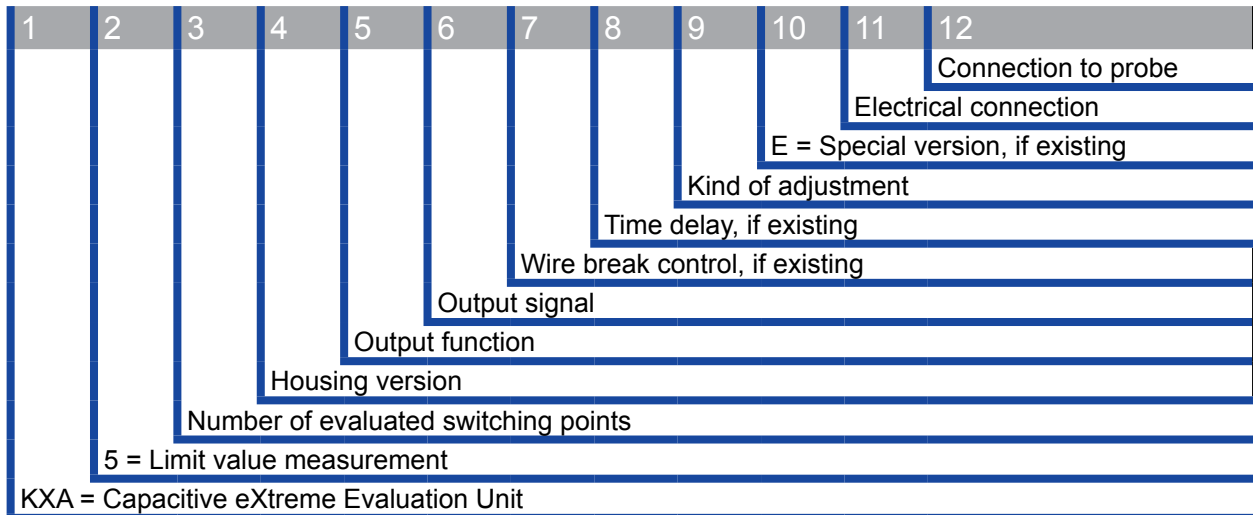

Position 3

Value	Number of evaluated switching points
1	1 switching point
1MINI	1 switching point, Evaluation unit for MINI-sensors
1/3	1 sensor with 3 switching points
1/3MINI	1 sensor with 3 switching points, Evaluation unit for MINI-sensors
1/4	1 sensor with 4 switching points
1/4MINI	1 sensor with 4 switching points, Evaluation unit for MINI-sensors
4	4 switching points
4MINI	4 switching points, Evaluation unit for MINI-sensors

Position 4

Value	Housing version in mm
B	46,6 x 74,5 x 30
L	55 x 96 x 25
LH	110 x 75 x 70
XXL	120 x 120 x 60

Position 5

Value	Output function
P	PNP transistor output
N	NPN transistor output
I	Relay output, 1 potential-free changeover contact
II	Relay output, 2 potential-free changeover contacts

Position 6

Value	Output Signal
S	Normally open (NO)
Ö	Normally closed (NC)
2S2Ö	2 x Normally open (NO) + 2 x Normally closed (NC)
A	Antivalent (NO + NC)
1CO	1 Change-over contact
2CO	2 Change-over contacts

TYPE CODE EVALUATION UNIT

Position 7

Value	Wire break control
Not specified	No Wire break control
FB	Wire Break control
1FB	Wire break control for 1 canal
2FB	Wire break control for 2 canals
3FB	Wire break control for 3 canals
4FB	Wire break control for 4 canals

Position 8

Value	Time delay
Not specified	No Time delay
TD	Time delay
1TD	Time delay for 1 canal
2TD	Time delay for 2 canals
3TD	Time delay for 3 canals
4TD	Time delay for 4 canals

Position 9

Value	Sensitivity adjustment
1	Potentiometer
0	Fix adjusted, no adjustment possible
ET	EasyTeach by Wire and EasyTeach by Button

Position 10

Value	Special version
Not specified	Standard version
E	Special version

Position 11

Value	Electrical connection
Not specified	Connection cable
Z0E	Special cable length
Z01	1 m connection cable
Z02	2 m connection cable
Z05	5 m connection cable
Z10	10 m connection cable
KL	Screw terminals

Position 12

Value	Connection to probe
Y90	Y95



Y95

Capacitive sensors Series KXS-eXtreme

Housing M 5 x 0.5

- Housing material: Stainless steel VA no. 1.4305 / AISI 303
- For connection to capacitive evaluation units KXA-...-MINI-...
- Extreme large sensing distance
- Up to 250° C ambient temperature



Technical data	Non-flush mountable
Operating distance S_n	3 mm
Operating distance min / max adjustable	0...5 mm
Type	KXS-250-M5/20-X-M5-PTFE/VAb-250C-X02/Y95
Art.-No.	498 000
Permitted ambient temperature	-50...+250 °C
Enclosure rating IEC 60529*	IP 67
Norm	EN 60947-5-2
Connection cable for connection to capacitive evaluation units KXA-...-MINI-... with plug-in connector	2 m FEP, Triax
Housing material	Stainless steel VA no. 1.4305 / AISI 303
Active surface	PTFE (FDA 21 CFR 177.1550)
Accessories (delivered with the sensor)	2 nuts M 5 x 0,5

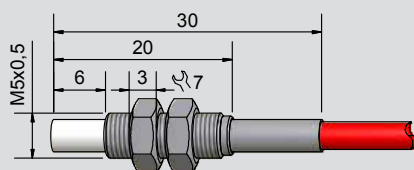

*Enclosure rating IEC 60529 for connector on request.



Y95

Capacitive sensors Series KXS-eXtreme

Housing M 8 x 1

- Housing material: Stainless steel VA no. 1.4305 / AISI 303
- For connection to capacitive evaluation units KXA-...-MINI-...
- Extreme large sensing distance
- Up to 250° C ambient temperature



Technical data	Non-flush mountable
Operating distance S_n	7 mm
Operating distance min / max adjustable	0...10 mm
Type	KXS-250-M8/25-X-M8-PTFE/VAb-250C-X02/Y95
Art.-No.	498 001
Permitted ambient temperature	-50...+250 °C
Enclosure rating IEC 60529*	IP 67
Norm	EN 60947-5-2
Connection cable for connection to capacitive evaluation units KXA-...-MINI-... with plug-in connector	2 m FEP, Triax
Housing material	Stainless steel VA no. 1.4305 / AISI 303
Active surface	PTFE (FDA 21 CFR 177.1550)
Accessories (delivered with the sensor)	2 nuts M 8 x 1

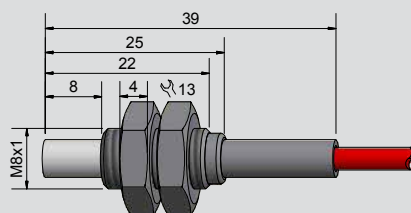

*Enclosure rating IEC 60529 for connector on request.



Y95

Capacitive sensors Series KXS-eXtreme

Housing M 12 x 1

- Housing material: Stainless steel VA no. 1.4305 / AISI 303
- For connection to capacitive evaluation units KXA-...-MINI-...
- Extreme large sensing distance
- Up to 250° C ambient temperature



Technical data	Non-flush mountable
Operating distance S_n	15 mm
Operating distance min / max adjustable	1...25 mm
Type	KXS-250-M12/25-X-M12-PTFE/VAb-250C-X02/Y95
Art.-No.	498 002
Permitted ambient temperature	-50...+250 °C
Enclosure rating IEC 60529*	IP 67
Norm	EN 60947-5-2
Connection cable for connection to capacitive evaluation units KXA-...-MINI-... with plug-in connector	2 m FEP, Triax
Housing material	Stainless steel VA no. 1.4305 / AISI 303
Active surface	PTFE (FDA 21 CFR 177.1550)
Accessories (delivered with the sensor)	2 nuts M 12 x 1

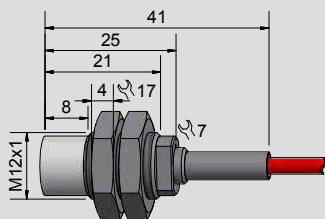

*Enclosure rating IEC 60529 for connector on request.



Y95

Capacitive sensors Series KXS-eXtreme

Housing M 16 x 1

- Housing material: PEEK
- For connection to capacitive evaluation units KXA-...-MINI-...-...
- Extreme large sensing distance
- Up to 250° C ambient temperature



Technical data	Flush mountable
Operating distance S_n	15 mm
Operating distance min / max adjustable	1...25 mm
Type	KXS-250-M16/30-X-M16-PEEK-250C-X02/Y95
Art.-No.	KX 0104
Permitted ambient temperature	-50...+250 °C
Enclosure rating IEC 60529*	IP 67
Norm	EN 60947-5-2
Connection cable for connection to capacitive evaluation units KXA-... with plug-in connector	2 m FEP, Triax
Housing material	PEEK (FDA 21 CFR 177.2415)
Active surface	PEEK (FDA 21 CFR 177.2415)

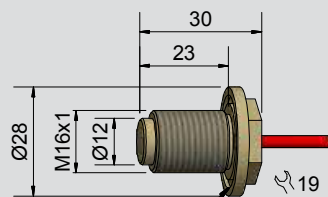

Groove for O-Ring 20 x 1,5

*Enclosure rating IEC 60529 for connector on request.



Y95

Capacitive sensors Series KXS-eXtreme

Housing M 18 x 1

- Housing material: Stainless steel VA no. 1.4305 / AISI 303
- For connection to capacitive evaluation units KXA-...
- Extreme large sensing distance
- Up to 250° C ambient temperature



Technical data	Non-flush mountable
Operating distance S_n	30 mm
Operating distance min / max adjustable	2...50 mm
Type	KXS-250-M18/70-X-M18-PTFE/VAb-250C-X02/Y95
Art.-No.	498 003
Permitted ambient temperature	-50...+250 °C
Enclosure rating IEC 60529*	IP 67
Norm	EN 60947-5-2
Connection cable for connection to capacitive evaluation units KXA-... with plug-in connector	2 m FEP, Triax
Housing material	Stainless steel VA no. 1.4305 / AISI 303
Active surface	PTFE (FDA 21 CFR 177.1550)
Accessories (delivered with the sensor)	2 nuts M 18 x 1

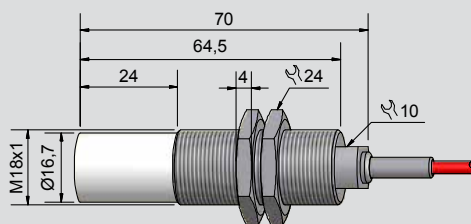

*Enclosure rating IEC 60529 for connector on request.

Made in Germany



Y95

Capacitive sensors Series KXS-eXtreme

Housing M 18 x 1

- Housing material: Stainless steel VA no. 1.4305 / AISI 303
- For connection to capacitive evaluation units KXA-...
- Extreme large sensing distance
- Up to 250° C ambient temperature



Technical data	Non-flush mountable
Operating distance S_n	30 mm
Operating distance min / max adjustable	2...50 mm
Type	KXS-250-M18/70-X-M18-PEEK/VAb-250C-X02/Y95
Art.-No.	KX 0097
Permitted ambient temperature	-50...+250 °C
Enclosure rating IEC 60529*	IP 67
Norm	EN 60947-5-2
Connection cable for connection to capacitive evaluation units KXA-... with plug-in connector	2 m FEP, Triax
Housing material	Stainless steel VA no. 1.4305 / AISI 303
Active surface	PEEK (FDA 21 CFR 177.2415)
Accessories (delivered with the sensor)	2 nuts M 18 x 1

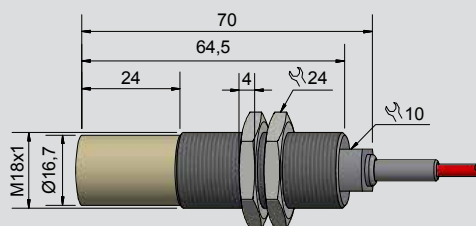

*Enclosure rating IEC 60529 for connector on request.

Made in Germany



Y95

Capacitive sensors Series KXS-eXtreme

Housing M 30 x 1.5

- Housing material: Stainless steel VA no. 1.4305 / AISI 303
- For connection to capacitive evaluation units KXA-...
- Extreme large sensing distance
- Up to 250° C ambient temperature



Technical data	Non-flush mountable
Operating distance S_n	60 mm
Operating distance min / max adjustable	5...100 mm
Type	KXS-250-M30/70-X-M30-PTFE/VAb-250C-X02/Y95
Art.-No.	498 004
Permitted ambient temperature	-50...+250 °C
Enclosure rating IEC 60529*	IP 67
Norm	EN 60947-5-2
Connection cable for connection to capacitive evaluation units KXA-... with plug-in connector	2 m FEP, Triax
Housing material	Stainless steel VA no. 1.4305 / AISI 303
Active surface	PTFE (FDA 21 CFR 177.1550)
Accessories (delivered with the sensor)	2 nuts M 30 x 1,5

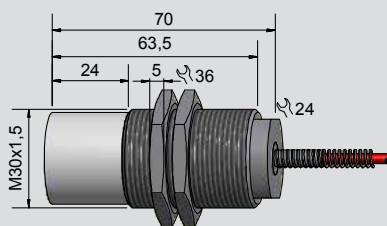

*Enclosure rating IEC 60529 for connector on request.



Y95

Capacitive sensors Series KXS-eXtreme

Housing M 30 x 1

- Housing material: PEEK
- For connection to capacitive evaluation units KXA-...-MINI-...
- Extreme large sensing distance
- Up to 250° C ambient temperature



Technical data	Flush mountable
Operating distance S_n	60 mm
Operating distance min / max adjustable	2...100 mm
Type	KXS-250-M30/22-X-M30-PEEK-250C-X02/Y95
Art.-No.	KX 0095
Permitted ambient temperature	-50...+250 °C
Enclosure rating IEC 60529*	IP 67
Norm	EN 60947-5-2
Connection cable for connection to capacitive evaluation units KXA-... with plug-in connector	2 m FEP, Triax
Housing material	PEEK (FDA 21 CFR 177.2415)
Active surface	PEEK (FDA 21 CFR 177.2415)

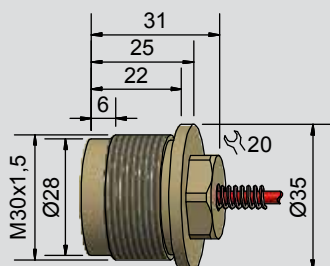

*Enclosure rating IEC 60529 for connector on request.

Made in Germany



Y95

Capacitive sensors Series KXS-eXtreme

Housing M 30 x 1.5

- Housing material: PTFE
- For connection to capacitive evaluation units KXA-...
- Extreme large sensing distance
- Up to 160° C ambient temperature



Technical data	Flush mountable
Operating distance S_n	60 mm
Operating distance min / max adjustable	5...100 mm
Type	KXS-250-M30/70-X-M30-PTFE-160C-X02/Y95-E
Art.-No.	KX 0073
Permitted ambient temperature	-50...+160 °C
Enclosure rating IEC 60529*	IP 67
Norm	EN 60947-5-2
Connection cable for connection to capacitive evaluation units KXA-... with plug-in connector	2 m FEP, Triax
Housing material	PTFE (FDA 21 CFR 177.1550)
Active surface	PTFE (FDA 21 CFR 177.1550)
Accessories (delivered with the sensor)	2 nuts M 30 x 1,5

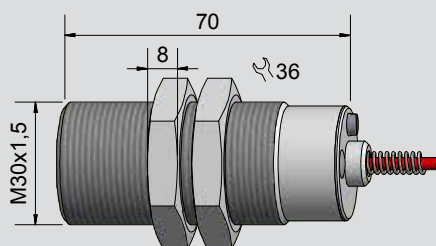

*Enclosure rating IEC 60529 for connector on request.



Y95

Capacitive sensors Series KXS-eXtreme

Housing Ø 30 mm

- Housing material: PTFE
- For connection to capacitive evaluation units KXA-...
- Extreme large sensing distance
- Up to 160° C ambient temperature



Technical data	Flush mountable
Operating distance S_n	20 mm
Operating distance min / max adjustable	2...30 mm
Type	KXS-250-30/70-X-D30-PTFE-160C-X0E/Y95
Art.-No.	KX 0087
Permitted ambient temperature	-25...+160 °C
Enclosure rating IEC 60529*	IP 67*
Norm	EN 60947-5-2
Connection cable for connection to capacitive evaluation units KXA-... with plug-in connector	0.3 m FEP, Triax
Housing material	PTFE (FDA 21 CFR 177.1550)
Active surface	PTFE (FDA 21 CFR 177.1550)

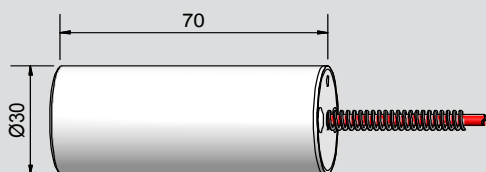

*Enclosure rating IEC 60529 for connector on request.



Y95

Capacitive sensors Series KXS-eXtreme

Housing M 32 x 1.5

- Housing material: Stainless steel VA no. 1.4305 / AISI 303
- For connection to capacitive evaluation units KXA-...
- Extreme large sensing distance
- Up to 250° C ambient temperature



Technical data	Non-flush mountable
Operating distance S_n	80 mm
Operating distance min / max adjustable	5...120 mm
Type	KXS-250-M32/70-X-M32-PTFE/VAb-250C-X02/Y95
Art.-No.	498 005
Permitted ambient temperature	-50...+250 °C
Enclosure rating IEC 60529*	IP 67
Norm	EN 60947-5-2
Connection cable for connection to capacitive evaluation units KXA-... with plug-in connector	2 m FEP, Triax
Housing material	Stainless steel VA no. 1.4305 / AISI 303
Active surface	PTFE (FDA 21 CFR 177.1550)
Accessories (delivered with the sensor)	2 nuts M 32 x 1,5

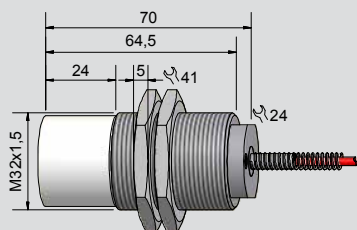

*Enclosure rating IEC 60529 for connector on request.

Made in Germany



Y95

Capacitive sensors Series KXS-eXtreme

Housing M 32 x 1.5

- Housing material: Stainless steel 1.4305 (AISI 303)
- For connection to capacitive evaluation units KXA-...
- Extreme large sensing distance
- Up to 250 °C ambient temperature



Technical data	Non-flush mountable
Operating distance S_n	80 mm
Operating distance min / max adjustable	5...120 mm
Type	KXS-250-M32/70-X-M32-PEEK/VAb-250C-X02/Y95
Art.-No.	KX 0022
Permitted ambient temperature	-50...+250 °C
Enclosure rating IEC 60529*	IP 67
Norm	EN 60947-5-2
Connection cable for connection to capacitive evaluation units KXA-... with plug-in connector	2 m FEP, Triax
Housing material	Stainless steel VA No. 1.4305 / AISI 303
Active surface	PEEK (FDA 21 CFR 177.2415)
Accessories (delivered with the sensor)	2 nuts M 32 x 1,5

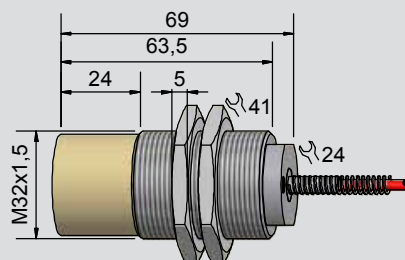

*Enclosure rating IEC 60529 for connector on request.

Made in Germany



Capacitive evaluation units Series KXA-eXtreme

Housing 46,6 x 74,5 x 30 mm

- KXA-...-MINI for connection to capacitive sensors KXS-...-M5/... to -M16/...



Technical data

Electrical version	4-wire DC
Output function	Antivalent
Type PNP	KXA-5-1MINI-B-P-A-1-Z02-Y90
Art.-No.	498 503
Operating voltage (U_B)	18...36 V DC
Voltage drop max. (U_d)	< 2.5 V
Permitted residual ripple max.	25 %
Operating current max. (I_o)	2 x 0...250 mA
No-load current (I_o)	Typ. 50 mA
Frequency of operating cycles max.	50 Hz
Switching hysteresis	≤ 20%
Repeat accuracy	≤ 1%
Permitted ambient temperature	-25...+55 °C
LED-display	Green / yellow
Protective circuit	Built-in
Degree of protection IEC 60529	IP 65
Norm	EN 60947-5-2
Connection cable	2 m, PUR, 4 x 0.14 mm ²
Housing material	PA

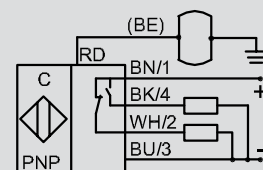
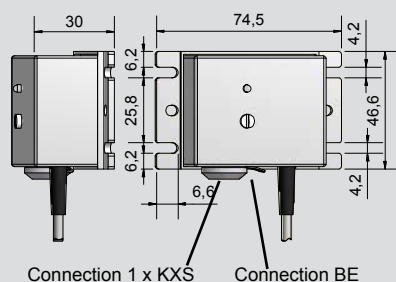

Made in Germany



Capacitive evaluation units Series KXA-eXtreme

Housing 46,6 x 74,5 x 30 mm

- KXA-... for connection to capacitive sensors KXS-...-M18/... to -M32/...



Technical data

Electrical version	4-wire DC
Output function	Antivalent
Type PNP	KXA-5-1-B-P-A-1-Z02-Y90
Art.-No.	498 500
Operating voltage (U_B)	18...36 V DC
Operating current max. (I_e)	2 x 0...250 mA
Voltage drop max. (U_d)	< 2.5 V
Permitted residual ripple max.	25 %
No-load current (I_o)	Typ. 50 mA
Frequency of operating cycles max.	50 Hz
Switching hysteresis	$\leq 20\%$
Repeat accuracy	$\leq 1\%$
Permitted ambient temperature	-25...+55 °C
LED-display	Green / yellow
Protective circuit	Built-in
Degree of protection IEC 60529	IP 65
Norm	EN 60947-5-2
Connection cable	2 m, PUR, 4 x 0.14 mm ²
Housing material	PA

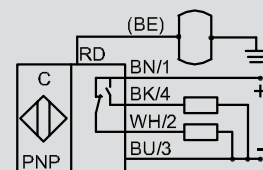
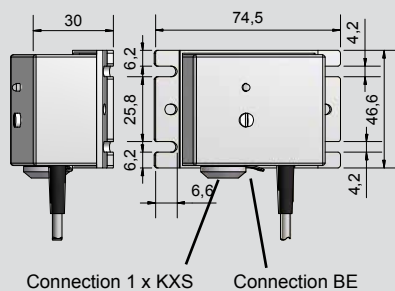



Capacitive evaluation units Series KXA-eXtreme

Housing 46,6 x 74,5 x 30 mm

- KXA-...-MINI for connection to capacitive sensors KXS-...-M5/... to -M16/...
- Adjustable with EasyTeach by Wire / EasyTeach by Magnet (ETM)



Technical data

Electrical version	4-wire DC
Output function	Antivalent
Type PNP	KXA-5-1MINI-B-P-A-ET-Z02-Y90
Art.-No.	XA 0065
Operating voltage (U_B)	18...36 V DC
Voltage drop max. (U_d)	< 2.5 V
Permitted residual ripple max.	25 %
Operating current (I_o)	2 x 0...200 mA
No-load current (I_o)	Typ. 50 mA
Frequency of operating cycles max.	50 Hz
Switching hysteresis	≤ 20%
Repeat accuracy	≤ 1%
Permitted ambient temperature	-25...+55 °C
LED-display	Green / yellow
Protective circuit	Built-in
Degree of protection IEC 60529	IP 65
Norm	EN 60947-5-2
Connection cable	2 m, PUR, 5 x 0.14 mm ²
Housing material	PA
Accessories (delivered with the unit)	Teach magnet

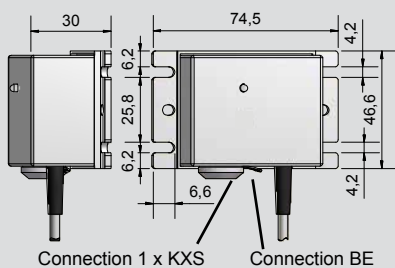

EasyTeach chart:

LED green / yellow

- Adjustment "empty"
- Initializing "empty"
- Adjustment "full"
- Initializing "full"
- Factory reset
- Test

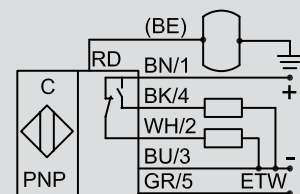



Capacitive evaluation units Series KXA-eXtreme

Housing 46,6 x 74,5 x 30 mm

- KXA-... for connection to capacitive sensors KXS-...-M18/... to -M32/...
- Adjustable with EasyTeach by Wire / EasyTeach by Magnet (ETM)



Technical data

Electrical version	4-wire DC
Output function	Antivalent
Type PNP	KXA-5-1-B-P-A-ET-Z02-Y90
Art.-No.	XA 0064
Operating voltage (U_B)	18...36 V DC
Voltage drop max. (U_d)	< 2.5 V
Permitted residual ripple max.	25 %
Operating current (I_o)	2 x 0...200 mA
No-load current (I_o)	Typ. 50 mA
Frequency of operating cycles max.	50 Hz
Switching hysteresis	≤ 20%
Repeat accuracy	≤ 1%
Permitted ambient temperature	-25...+55 °C
LED-display	Green / yellow
Protective circuit	Built-in
Degree of protection IEC 60529	IP 65
Norm	EN 60947-5-2
Connection cable	2 m, PUR, 5 x 0.14 mm ²
Housing material	PA
Accessories (delivered with the unit)	Teach magnet

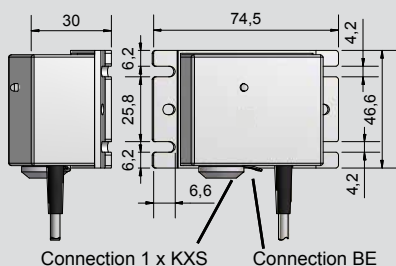

EasyTeach chart:

LED green / yellow

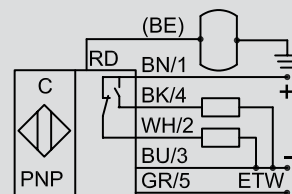
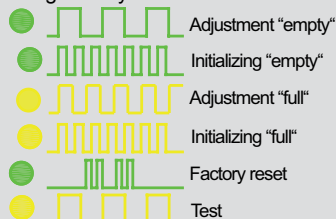



Capacitive Evaluator Series KXA-eXtreme

Housing 120 x 120 x 60 mm

- KXA-... for connection of 4 capacitive Sensors KXS-...-M18/... to -M32/...
- Extension by further switching points possible (master / slave function)



Technical data

Output function	4 x Antivalent
Type PNP	KXA-5-4-XXL-P-A-1-KL-Y90
Art.-No.	XA 0022
Operating voltage (U_B)	18...36 V DC
Operating current max. (I_o)	0...250 mA each output
Permitted residual ripple max.	25 %
No-load current (I_o)	Typ. 120 mA
Permitted ambient temperature	-25...+55 °C
LED - display	Green / yellow
Protective circuit	Built-in
Degree of protection IEC 60529	IP 54
Norm	EN 60947-5-2
Connection	Screw terminals and triax socket
Housing material	ABS

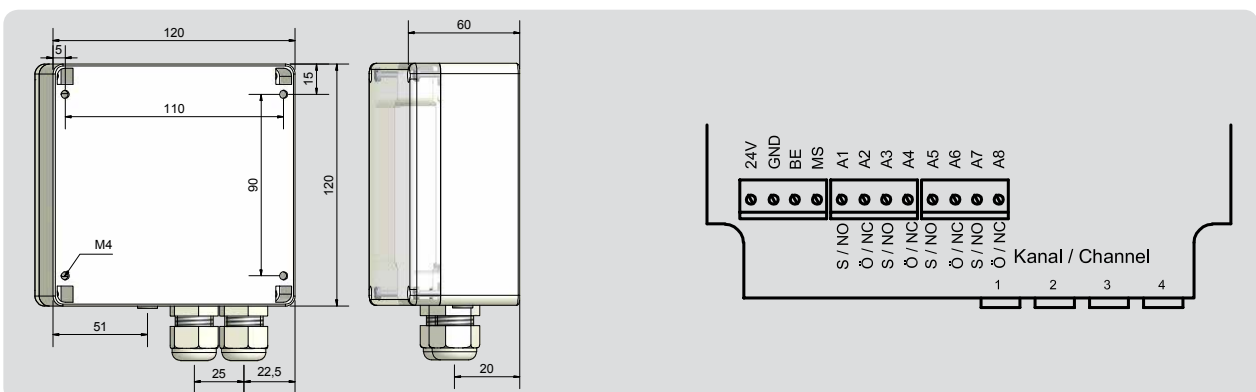

Made in Germany



Capacitive Evaluator Series KXA-eXtreme

Housing 120 x 120 x 60 mm

- KXA-...MINI for connection of 4 capacitive Sensors KXS-...-M5/... to -M16/...
- Extension by further switching points possible (master / slave function)



Technical data

Output function	4 x Antivalent
Type PNP	KXA-5-4MINI-XXL-P-A-1-KL-Y90
Art.-No.	XA 0026
Operating voltage (U_B)	18...36 V DC
Operating current max. (I_o)	0...250 mA each output
Permitted residual ripple max.	25 %
No-load current (I_o)	Typ. 120 mA
Permitted ambient temperature	-25...+55 °C
LED - display	Green / yellow
Protective circuit	Built-in
Degree of protection IEC 60529	IP 54
Norm	EN 60947-5-2
Connection	Screw terminals and triax socket
Housing material	ABS

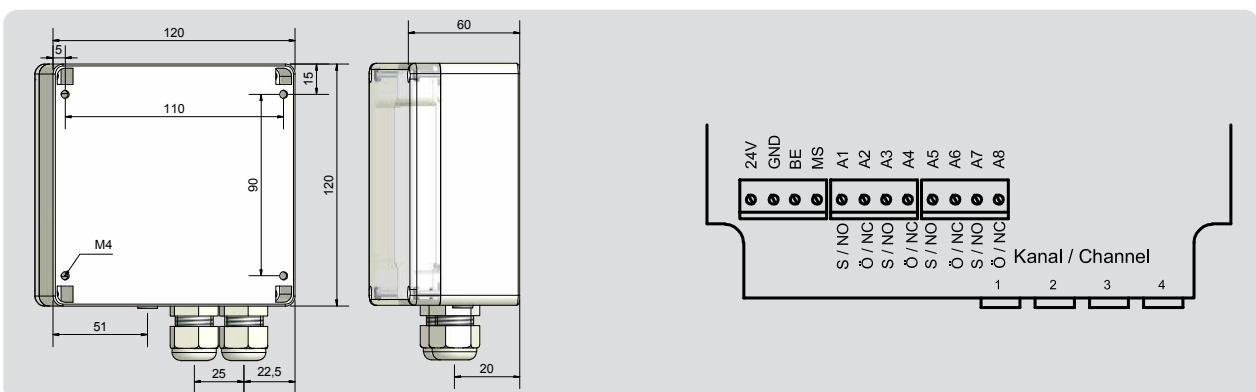

Made in Germany



Capacitive sensors Series KXC-eXtreme

Housing 120 x 80 x 30 mm

- Housing material: PBT
- Sensor and evaluation unit integrated in one housing
- Extreme large sensing distance



Technical data

Operating distance S_n	120 mm
Operating distance min / max adjustable	20...200 mm
Electrical version	4-wire DC
Output function	Antivalent
Type PNP	KXC-5-1-C65/30-P-A-120x80x30-PBT-Z02
Art.-No.	KX 0085
Operating voltage (U_B)	18...36 V DC
Output current max. (I_e)	2 x 0...250 mA
Voltage drop max. (U_o)	< 2.5 V
Permitted residual ripple max.	25 %
No-load current (I_o)	Typ. 50 mA
Frequency of operating cycles max.	4 Hz
Permitted ambient temperature	-25...+55 °C
LED-display	Green / yellow
Protective circuit	Built-in
Degree of protection IEC 60529	IP 65
Norm	EN 60947-5-2
Connection cable	2 m, PVC, 4 x 0.34 mm ²
Housing material	PBT
Active surface	PBT
Lid	PBT

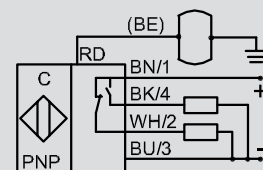
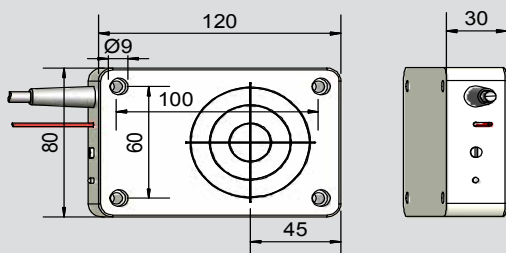



ATEX with Manufacturer Certificate

Device Category	Zone classification
1G	For use in Zone 0
1D	For use in Zone 20
2G	For use in Zone 1
2D	For use in Zone 21
3G	For use in Zone 2 (gas)
3D	For use in Zone 22 (dust)

Safety is important to your company. The KXS-eXtreme Series is also available for your hazardous area. Our devices can also be used in Zone 2 and Zone 22.

KXS-eXtreme with ATEX

3G 3D

Zone 2 / Zone 22

Protection and safety

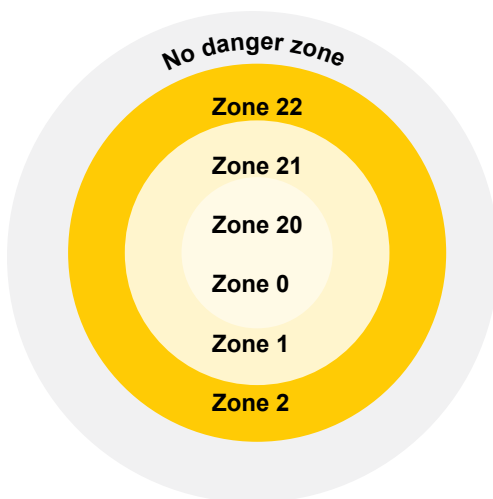

Potentially explosive atmosphere area

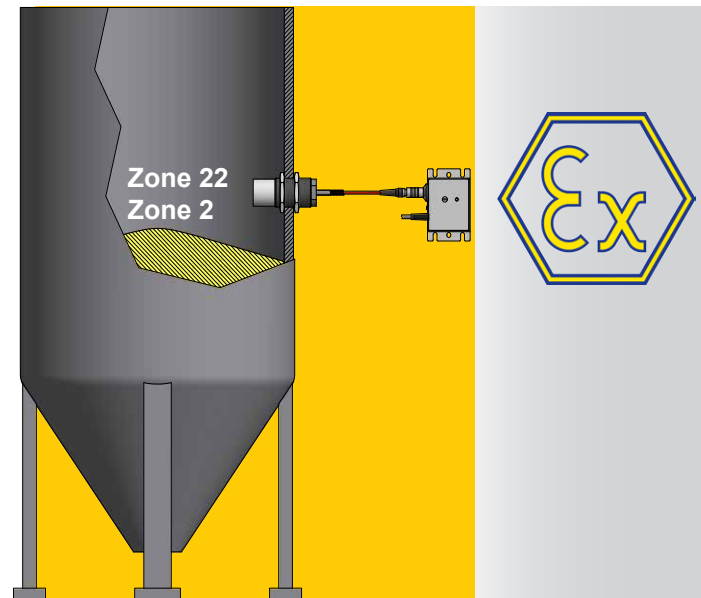

Zone classification for gases, vapours or mists			
Zones		Definition	Risk potential
Gas	Dust		
0	20	Areas where a potentially explosive atmosphere comprising dust / air mixture is present continuously, over extended periods, or frequently	Constantly
1	21	Areas where it is expected that a hazardous potentially explosive atmosphere comprising dust / air mixtures will occur occasionally and for short periods.	Occasionally
2	22	Areas where it is not to be expected that a potentially explosive atmosphere will occur. If this does occur, then in all probability only rarely and for a short period .	Short-term



Y95

Capacitive sensors Series KXS-eXtreme - ATEX

Housing M 30 x 1.5

- Housing material: Stainless steel VA No. 1.4305 / AISI 303
- For connection to capacitive evaluation units KXA-...-MINI-...
- Extreme large sensing distance
- Up to 250° C ambient temperature

With manufacturer certificate

for use in zone 2 (gas)

Ex II 3G Ex nA IIC T6 Gc X

for use in zone 22 (dust)

Ex II 3D Ex mc IIIC T101°C Dc IP67 X



Technical data

Operating distance S_n	Non-flush mountable 60 mm
Operating distance min / max adjustable	5...100 mm
Type	KXS-M30/70-3G-3D
Art.-No.	KX 0094
Permitted ambient temperature	-50...+250 °C
Enclosure rating IEC 60529*	IP 67
Norm	EN 60947-5-2
Connection cable for connection to capacitive evaluation units KXA-... with plug-in connector	2 m FEP, Triax
Housing material	Stainless steel VA No. 1.4305 / AISI 303
Active surface	PTFE (FDA 21 CFR 177.1550)
Accessories (delivered with the sensor)	2 nuts M 30 x 1,5

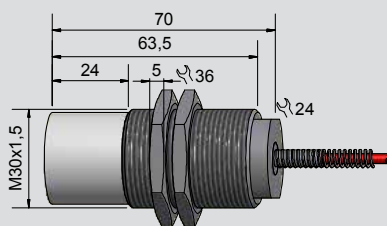

*Enclosure rating IEC 60529 for connector on request.



Capacitive evaluation units Series KXA-eXtreme - ATEX

Housing 46,6 x 74,5 x 30 mm

- KXA-... for connection to capacitive sensors KXS-...-M18/... to -M32/...

With manufacturer certificate

for use in zone 2 (gas)

for use in zone 22 (dust)

Ex II 3G Ex nA IIC T6 Gc X

Ex II 3D Ex mc IIIC T101°C Dc IP67 X



Technical data

Electrical version	4-wire DC
Output function	Antivalent
Type PNP	KXA-5-1-P-A-3G-3D
Art.-No.	XA 0028
Operating voltage (U_B)	18...30 V DC
Operating current max. (I_o)	2 x 0...150 mA
Voltage drop max. (U_d)	< 2.5 V
Permitted residual ripple max.	25 %
No-load current (I_o)	Typ. 50 mA
Frequency of operating cycles max.	50 Hz
Switching hysteresis	$\leq 20\%$
Repeat accuracy	$\leq 1\%$
Permitted ambient temperature	-25...+55 °C
LED-display	Green / yellow
Protective circuit	Built-in
Degree of protection IEC 60529	IP 65
Norm	EN 60947-5-2
Connection cable	2 m, PUR, 4 x 0.14 mm ²
Housing material	PA

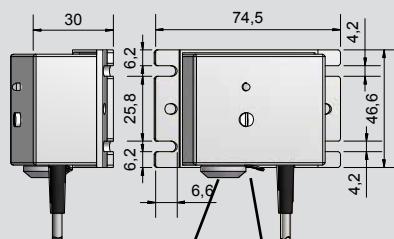

Connection 1 x KXS

Connection BE

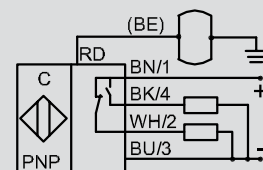

Made in Germany

RECHNER

Алматы (727)345-47-04
Ангарск (3955)60-70-56
Архангельск (8182)63-90-72
Астрахань (8512)99-46-04
Барнаул (3852)73-04-60
Белгород (4722)40-23-64
Благовещенск (4162)22-76-07
Брянск (4832)59-03-52
Владивосток (423)249-28-31
Владикавказ (8672)28-90-48
Владимир (4922)49-43-18
Волгоград (844)278-03-48
Вологда (8172)26-41-59
Воронеж (473)204-51-73
Екатеринбург (343)384-55-89

Россия +7(495)268-04-70

Иваново (4932)77-34-06
Ижевск (3412)26-03-58
Иркутск (395)279-98-46
Казань (843)206-01-48
Калининград (4012)72-03-81
Калуга (4842)92-23-67
Кемерово (3842)65-04-62
Киров (8332)68-02-04
Коломна (4966)23-41-49
Кострома (4942)77-07-48
Краснодар (861)203-40-90
Красноярск (391)204-63-61
Курск (4712)77-13-04
Курган (352)50-90-47
Липецк (4742)52-20-81

Казахстан +7(727)345-47-04

Магнитогорск (3519)55-03-13
Москва (495)268-04-70
Мурманск (8152)59-64-93
Набережные Челны (8552)20-53-41
Нижегород (831)429-08-12
Новокузнецк (3843)20-46-81
Ноябрьск (3496)41-32-12
Новосибирск (383)227-86-73
Омск (3812)21-46-40
Орел (4862)44-53-42
Оренбург (3532)37-68-04
Пенза (8412)22-31-16
Петрозаводск (8142)55-98-37
Псков (8112)59-10-37
Пермь (342)205-81-47

Беларусь +(375)257-127-884

Ростов-на-Дону (863)308-18-15
Рязань (4912)46-61-64
Самара (846)206-03-16
Санкт-Петербург (812)309-46-40
Саранск (8342)22-96-24
Саратов (845)249-38-78
Севастополь (8692)22-31-93
Симферополь (3652)67-13-56
Смоленск (4812)29-41-54
Сочи (862)225-72-31
Ставрополь (8652)20-65-13
Сургут (3462)77-98-35
Сыктывкар (8212)25-95-17
Тамбов (4752)50-40-97
Тверь (4822)63-31-35

Узбекистан +998(71)205-18-59

Тольятти (8482)63-91-07
Томск (3822)98-41-53
Тула (4872)33-79-87
Тюмень (3452)66-21-18
Улан-Удэ (3012)59-97-51
Ульяновск (8422)24-23-59
Уфа (347)229-48-12
Хабаровск (4212)92-98-04
Чебоксары (8352)28-53-07
Челябинск (351)202-03-61
Череповец (8202)49-02-64
Чита (3022)38-34-83

Якутск (4112)23-90-97
Ярославль (4852)69-52-93

Киргизия +996(312)96-26-47